

## Operation manual for the NAVEE scooter N65

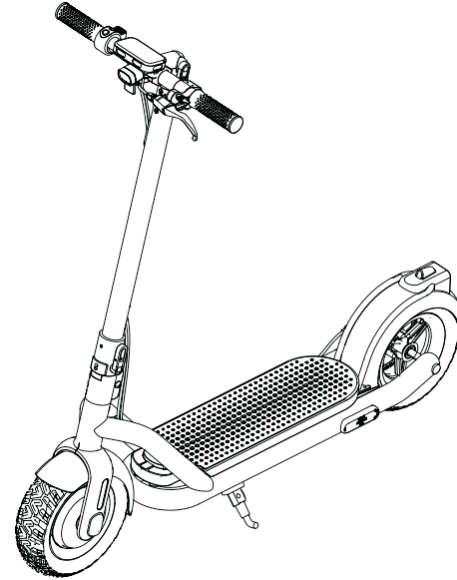

---

Standard used: UL 2272:2016 FCC

The pictures and functions described in this paper are for illustration and reference purposes only. The products described should be subject to the actual, real objects. The technical performance indicators mentioned are based on the specific experimental environment, and the actual indicators may vary according to design and environment. The safety protection components of this product are only used for auxiliary safety management, which can not replace other safety measures. Do not use this product for any illegal purpose.

---

The pictures are for reference only. Please read the product manual before using the product.  
-----Warranty card included

# Contents

---

1. Products & accessories -----	2
2. Introduction to functions-----	3
3. Safety instructions-----	4
4. Product display-----	8
5. Correct riding method-----	9
6. Handlebar control-----	10
7. Open case assembly of scooter-----	11
8. Deployment steps-----	12
9. Folding steps-----	13
10. Charging-----	14
11. Handling-----	14
12. Basic operation-----	15
13. Operating instructions-----	16
14. Riding instructions-----	17
15. Batteries and chargers-----	18
16. LED display-----	19
17. Maintenance-----	22
18. Common problems and solutions-----	23
19. Parameter configuration-----	24
20. Warranty and service-----	25
21. Warranty card-----	27

## Welcome

---

Thank you for choosing the NAVEE electric scooter N65 (hereinafter referred to as “N65”). Now you can experience the pleasure of riding your own electric scooter. It should be pointed out that the N65 is only a small-sized electric scooter intended for individual riding, It is not suitable for acrobatic use.

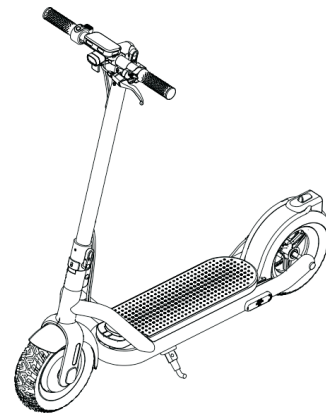

Manufacturer: Zhejiang Feishen Vehicle Industry Co., Ltd

## 1 Products & accessories

Scooter body

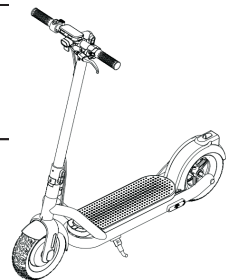

Parts

Operation manual for the N65 scooter



Manual

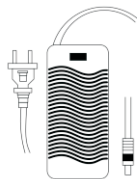

Power adapter



M4, M5 wrench



Warning!

Please check carefully to ensure the items in the packing box are complete and in good condition

To prevent accidents, please place the packaging bags, plastic bags and product accessories in locations which are out of the reach of children

## 2 Introduction to functions

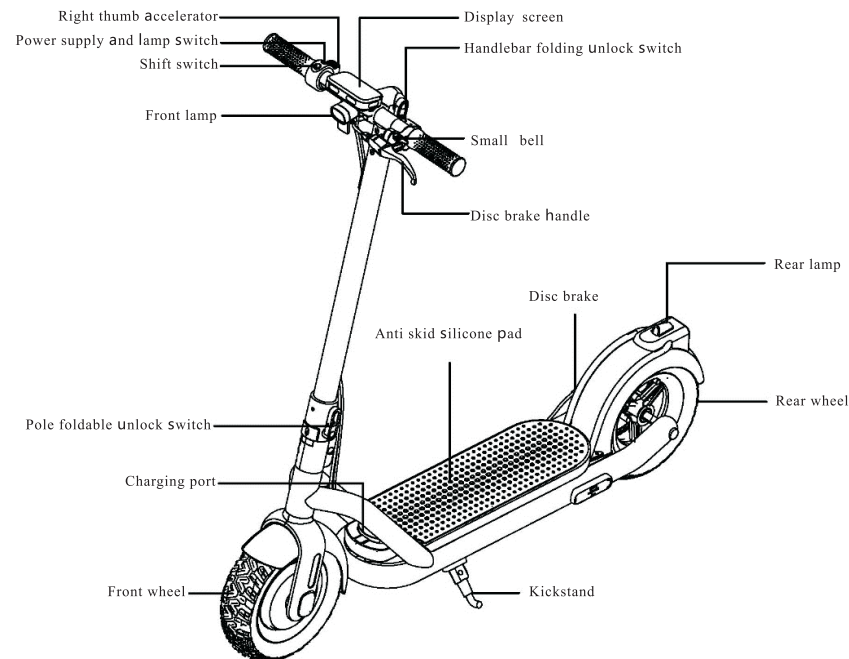

### 3 Safety instructions

Note: before using the product, please carefully read and follow the following important safety information.

1. This product can only be used by one person. Do not carry others at the same time while you are riding. The product is recommended for use by riders over the age of 13 and under the age of 65. Other persons who are not suitable for riding this product include: (1) persons under the influence of alcohol or drugs (2) persons unable to engage in strenuous physical activities due to illness (3) persons who are incapable of keeping their balance or who cannot keep their balance due to impaired motor skills (4) persons whose weight exceeds the prescribed limit (5) pregnant women (6) persons who suffer from visual and/or hearing impairment.



3. Do not ride this product in areas in which it is unsafe or illegal to ride, or on unsafe or off-limits roads.



2. When riding this product, please wear a safety helmet and , suitable protective devices. Do not ride barefoot or in high-heeled shoes.

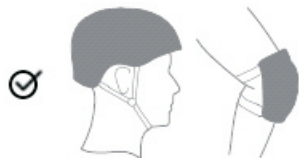

4. It is forbidden to ride this product on public roads and motorways.

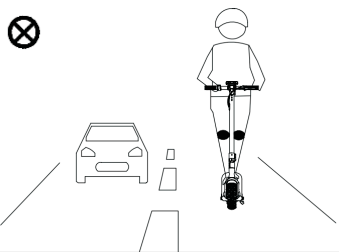

5. Do not engage in any dangerous actions during driving, such as riding with one leg or one hand. Make sure that both of your legs and hands are on the scooter.

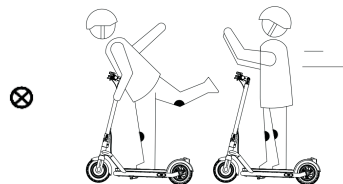

7. For your driving safety, please maintain a speed within 25 km/h while riding. Please try to avoid riding at night. If you are required to ride at night, please turn on the lamps and maintain a speed within 15 km/h.

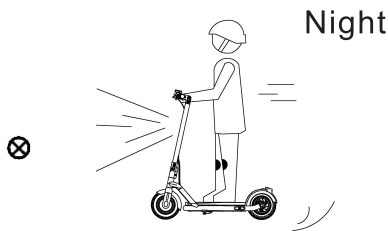

6. Do not attempt to ride over or pass steps , curbs or other obstacles that have a height of more than 3 cm, since doing so may cause the scooter to overturn and thereby cause personal injury to the driver or damage to the product; steps, curbs and/or other obstacles with a height under 3 cm should also be avoided as far as possible.

Do not park the scooter on an incline.



8. Do not use this product in an environment with a temperature below - 10 °C .



9. Should you find yourself riding the scooter on a road which has been unevenly paved, or should you encounter other poor road conditions, please allow yourself sufficient time to stop the scooter safely, and then either ride slowly or dismount so that you can push the scooter as you walk. A scooter is a very special riding product, so please try to ride on flat, evenly-paved roads without potholes.



11. Do not immerse the scooter in water with a depth of more than 4 cm, to avoid damage to the scooter's battery.

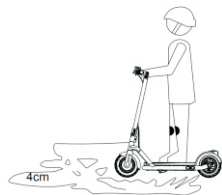

10. Do not ride on surfaces where oil or ice are present.



12. Please do not drive the scooter in wet, rainy, snowy or icy conditions. Do not drive the scooter over any obstacles (e.g. sand, loose gravel or road blocks). Doing so may cause you to lose your balance or your grip, which can result in personal injury. If you are required to ride on rainy days, please maintain your distance from other vehicles and avoid sudden or abrupt braking.



Safety tip: do not hang or place any objects on the scooter's handlebars or on the body of the scooter while riding.

13. Do not use this product to carry a load which exceeds its specified maximum loading capacity (120 kg).

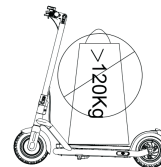

15. Users should ride safely and lawfully, in strict accordance with local laws and regulations.

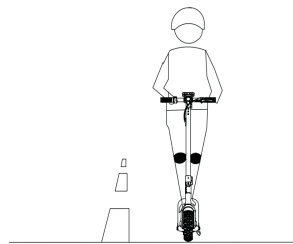

14. Please avoid using or placing the product in any environment with a temperature above 40 °C or a temperature below -10 °C. Please do not place this product together with or in the vicinity of flammable substances so as to avoid fire and/or other accidents.

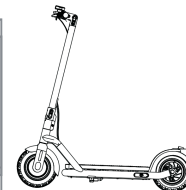

## 4. Product display

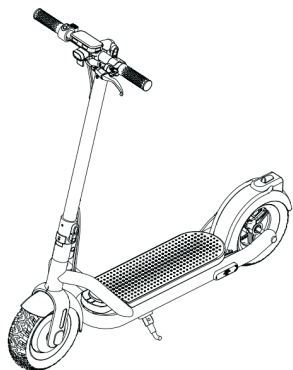

Expanded state

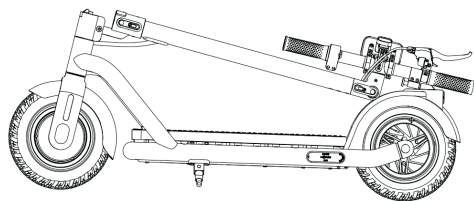

Folded state

## 5. Correct riding method

1. Check the scooter before each ride, and ride only after the folding safety lock has been locked.
2. Wear well-fitting, flat-heeled sports shoes to ride this product.
3. Please practice riding in an open space.
4. Keep away from vehicles and crowded areas. Please ride on roads or in areas which are designated in accordance with local laws.
5. Safety helmet and protective equipment must be worn while riding.
6. The rider should be over the age of 13 years (inclusive) and under the age of 65 years (inclusive).
7. It is forbidden to ride the scooter on uneven ground. If you encounter any obstacles, please stop riding and fold up or adjust the scooter to walking mode in order to cross/pass the obstacle or blocked passage.
8. Avoid riding in rainy and/or snowy weather and/ or at night, and keep away from cars to avoid sudden braking.
9. The maximum load-bearing capacity of the product (user plus luggage) is 120 kg.
10. The height of the rider should be over 1.4 m (inclusive) and under 2.2 m (inclusive).
11. It is forbidden to hang or place objects on the scooter body and/or handlebars.
12. This product is a personal riding product and cannot be used for acrobatic riding.
13. Users should abide by local laws and regulations.
14. It is recommended that you check the front and rear lamps before each ride.
15. Do not perform any unauthorized modifications or alterations on this product.
16. Do not use replacement parts other than professional parts provided by the original manufacturer

Do not use any replacement parts other than those parts provided by the manufacturer by the manufacturer's designated repairer. You must understand that following the tips and warnings in this manual can reduce risks, but that doing so cannot eliminate all risks. Please remember that there is always a risk of losing control, of falling and of becoming involved in a collision while using the scooter. When you enter a public area, please observe and abide by all local laws and regulations. Just like all vehicles, the faster you drive a scooter, the longer it takes to brake. On some types of smooth ground, emergency braking may also cause one or both of the wheels to slip and/or the driver to fall. It is therefore very important to stay alert and maintain a reasonable, safe distance from other vehicles as well as people. Keep alert and maintain a low speed when entering unfamiliar terrain.

### Warning!

- (1) This product must be ridden on those roads and in those areas designated by local laws. It is forbidden to ride outside of these roads and areas which have been designated in accordance with laws and regulations. Riding on the expressway is also forbidden.
- (2) When crossing/passing obstacles, stop riding and fold the scooter up or slow down to pass safely
- (3) Please ring the bell to warn passing pedestrians.

Check before riding. The folding safety lock can be locked before riding



## 6 Control of the handlebars

1. Hold the handlebar with both hands, not with one hand.
2. Turn in the appropriate direction, hold the handlebar tightly and turn left and right.
3. Do not rotate the handlebar 360°.
4. The handbrake and the bell are on the left side of the handlebar.
5. Hold the brake with your left hand.
6. The power switch and speed control key are on the right side of the handlebar.
7. When riding, press the speed control key with your right thumb.
8. Please ring the scooter bell when you are in a crowded place.
9. In non-zero start mode, slide forward for a certain distance and the speed exceeds 4 km / h. Press the right thumb accelerator to ride.
10. You are not permitted to place a basket on the front of the scooter.

### ⚠ Warning!

- 1) When riding, please do not hang heavy objects on the body of the scooter and/or on the handlebars, since doing so will impair the stability of the scooter, thereby producing potential safety hazards.
- 2) Check regularly to see whether the screw part of the handlebar has come loose, as well as whether the frame, fork, brake and other parts are functioning normally. Should the scooter parts become damaged, please stop using/riding the scooter and arrange to repair or replace the parts as soon as possible.

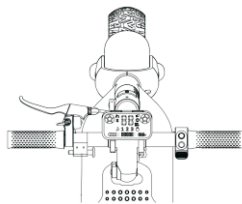

## 7. Open case assembly of scooter

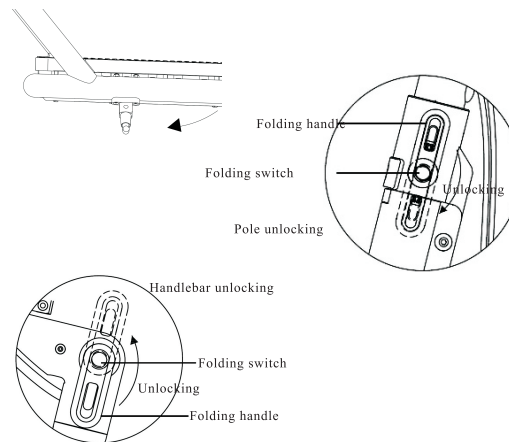

The scooter unfolds and opens the foot brace

(Mainly refer to 8 deployment steps)

- a. Pull out the mushroom head pull pin in the direction of the arrow.
- b. After erecting the vertical pole, turn the folding handle 180 ° counter-clockwise to lock.
- c. Turn the handlebar folding handle 180 ° counter-clockwise for lock.
- d. Turn the handlebar 90 ° counter-clockwise. The folding handle can be locked after returning to its original position.



**Safety tip:** before each ride, please check to ensure that the screw, folding switch and other link parts are not loose.

## 8 Deployment steps

1. Open the foot support bracket.

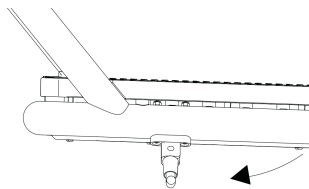

2. Pull the mushroom head bolt in the direction of the arrow.

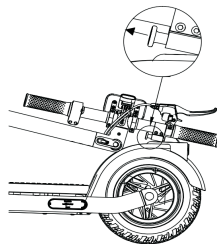

3. After erecting the vertical pole, turn the folding handle 180 ° counter-clockwise to lock.

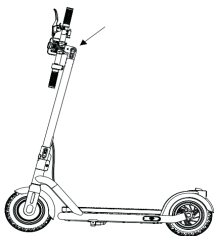

4. Turn the handlebar 90 ° counter-clockwise. The folding switch can be locked after returning to its original position



**Safety tip:** when lifting the front part of the N65 scooter, do not put your hand between the seams.

## 9 Folding steps

Note: for your safety, turn off the power before folding. Since the product can be folded, do not step on or turn the folding handle when riding.

1. First press the folding switch and turn the folding handle 180 ° counter-clockwise . Turn the handlebar 90 ° 180 ° counter- clockwise. Then put down the pole.
2. Press the folding switch and rotate the folding handle 180 ° counter-clockwise . Turn the handlebar 90 ° 180 ° counter- clockwise. Then put down the pole.

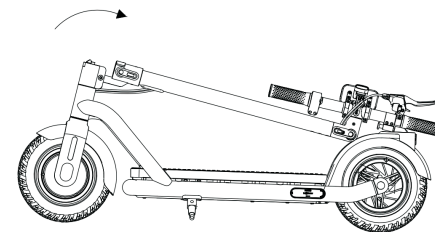
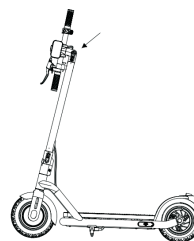

3. Pull out the mushroom head pin and clip it into the pin hole of the upper cover of the fender.
4. Fold up the foot support bracket to complete the folding.

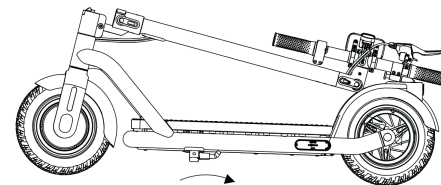
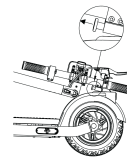



## 10 Charging

Note: Please always use the original charger to charge the scooter.

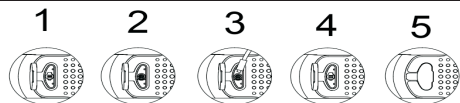
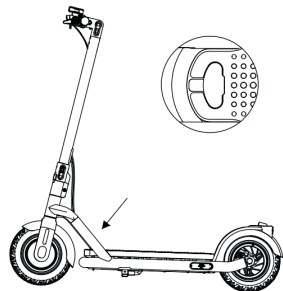

1. Open the waterproof cover of the charging port.
2. Open the rubber plug of the charging port.
3. Close the rubber plug after charging.
4. Close the rubber plug after charging.
5. Tighten the waterproof cover of the charging port.

When the charger's LED lamps glow red, this means it is charging, Once the charger's LED lamp turns green, this means that the battery is fully charged.

### Warning!

- 1) Do not touch the interface when charging. Risk of electric shock.!
- 2) Please check whether the power switch is off before charging.
- 3) Do not turn on the power switch when charging
- 4) Do not use this product when charging to avoid the damage.
- 5) It is recommended that you charge at 0-45 °C .
- 6) Please keep the scooter body away from heat sources, open flames, as well as flammable and explosive gas (liquid).

## 11 Handling

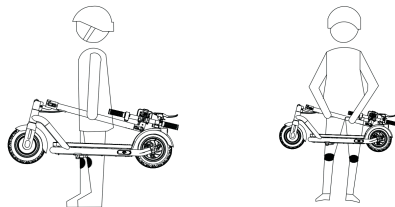

After folding, the scooter can be handled/carried using one or two hands.

## 12 Basic operation

- A: Speed control                      B: Power switch button                      C: Gear shift button  
D: Instrument display                      E: Bell                      F: Brake control

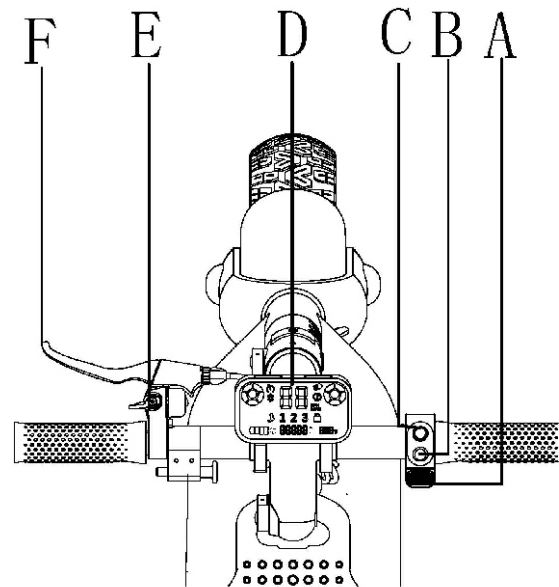

## 13 Operating instructions

---

### Power switch

Briefly press the power button for 3 seconds to turn on the scooter. After powering on, press the power button for 3 seconds to turn off the scooter.

### Gear setting

Press the shift button once to shift gears.

### Speed control

Switch between zero start mode and non-zero start mode, press the gear control button three times. Press the right thumb accelerator to allow the user to control the speed range (1-32km/h).

### Speed control

Hold the brake control on the left to brake. The greater the holding force, the greater the braking force. When braking quickly, it is easy to fall down due to the loss of traction, which puts you at risk of serious injury. Please keep driving at medium speed and pay attention to potential dangers.

### LED from lamp switch

In the power-on state, click the power key to turn the front lamp on and off.

### Emergency braking

In case of emergency, hold the left brake tightly to control the brake, which can activate the rear wheel friction brake and the front wheel electromagnetic brake at the same time. In order to avoid riding risk and damage to the rear wheels, the rear emergency brake should not be used during normal driving within the speed control range.

### Tire pressure

Before riding, please make sure that the tire pressure is not lower than 210KPA and the maximum pressure is not higher than 230KPA. If the tire pressure is too high, this will create a risk of bursting. If the tire pressure is too low, the mileage will become reduced and the tire will become damaged. If the scooter is not used for a long period of time, the tire pressure may also become lower than the standard ( Note: solid tire is not in the scope of requirements.).

## 14 Riding instructions

---

### Start riding

1. Press the power button to turn on the power.
2. Keep one foot on the pedal and the other foot on the ground.
3. Slide the scooter body forward and gently press the right thumb



- accelerator. The scooter will move forward slowly.
4. When riding, hold the handlebars tightly with both hands to avoid losing your balance, which can result in falling and/or injury.
5. Once the scooter is running smoothly, move the other foot onto the pedal. Use your right thumb to press the right thumb accelerator. The greater the accelerator angle, the faster the scooter speed.

### Riding preparation

1. Choose an open space suitable for riding.
2. Ride on a road that is flat and even.
3. Unfold the product according to the instructions and wear protective equipment.
4. Wear sneakers that fit your feet well.
5. Keep away from vehicles and crowded places.
6. Protect yourself and others in all circumstances.

### Parking

1. Under normal circumstances, if you hold the left brake handle, the scooter will power off and brake immediately.

The greater the grip angle, the greater the braking force.

2. In case of emergency, hold the left brake lever tightly to realize the front wheel electromagnetic braking and rear wheel friction braking. The rear brake disc will heat up rapidly in use. Please do not touch it.

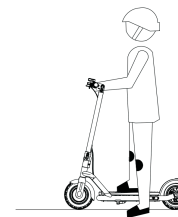

Note: in order to ride safely, the NAVEE scooter N65 is equipped with non-zero start. Scooters equipped with non-zero start can only deploy the accelerator function after sliding forward for a certain distance.

## 15 Battery and charger

Each NAVEE scooter N65 is equipped with a dedicated lithium battery and a dedicated smart charger. Each scooter and its accessories are equipped with a special number. Do not use other brands of charger, as other types of chargers are not suitable for this product.

### Battery

Ex-factory voltage is 48 ~ 51 VDC, rated voltage is 48 V, maximum charging voltage is 54.6 V, and rated capacity is 12.5 AH. The lithium battery provided by our company can be recharged at least 500 times, and normal battery capacity can attain over 80%.

### Charger

The special charger provided is equipped with overcharge protection. When the battery is fully charged, the charger will automatically power off. Full charge time is 7-8 hours. Please note that battery damage caused by water immersion, collision and other abnormal use factors is not within the scope of warranty policy. If the charging port or charging line is wet, please do not connect the charger.

### Kinetic energy recovery

During driving, pressing the brake will activate the kinetic energy recovery system. This will convert part of the kinetic energy generated into electrical energy for storage and utilization. The kinetic energy recovery system can also enhance emergency braking. At the same time, the recovered kinetic energy can help to increase endurance, with changes appearing in the power display.

**Safety tip: do not remove the external lithium battery while charging.**

## 16 LED display

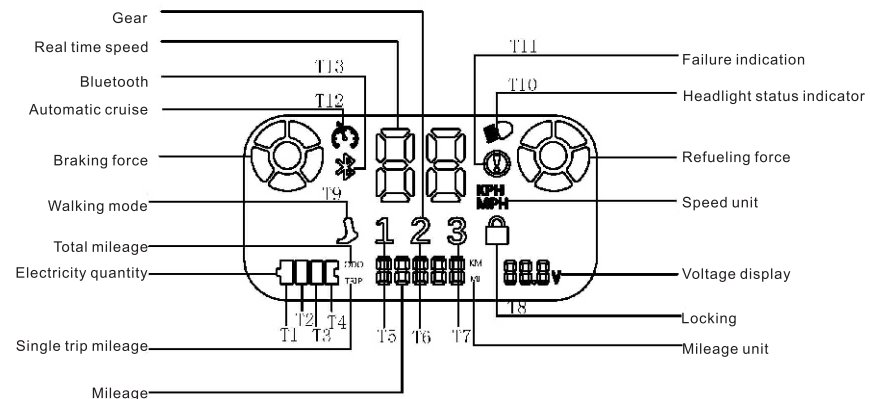

Power indicator Definition of LED:

Power of each meter is 4 grids (with the leftmost grid flashing, 4 grids are used for 5 grids, 20% for each grid), and the minimum power is on from the left.

100%~80%	80%~60%	60%~40%	40%~20%	<20%
T1-T4 On	T1-T3 On	T1-T2 On	T1 On	T1 flashes

Headlamp status indicator:

Open	Close
If the front lamp setting is turned on, the indicator lamp will always remain turned on.	If the front lamp setting is turned off, the indicator lamp will remain turned off.
T10 On	T10 Off

Third gear indication:

First gear	Second gear	Third gear
First gear on	Second gear on	Third gear on
T5 On . T6/T7 Off	T6 On . T5/T7 Off	T7 On . T5/T6 Off

Instrument on / off:

Power off mode: press the power button for three seconds to power off.

Power on mode: press the power button for three seconds to power on.

Press the power button

briefly

Turn headlight on / off

Cycle: on to off to on

Gear switch

Operation mode, click the gear shift button

Cycle: T5 ~ T6 ~ T7 ~ T9 ~ T5

Save the last enabled level after closing

Cycle: T5 ~ T6 ~ T7 ~ T9 ~ T5

Save the last enabled level after closing

Save the last enabled level after closing

The warning LED lamp is flashing and the display values E1-E7 are flashing.

Fault	Code	Solution	
Rx communication failure	E1	Please check whether the braking tail light is on. If it is not on, the controller power is not supplied. Replace the controller or instrument. If it is on, please check whether the connecting line from the instrument to the controller is open.	
Braking failure	E2	Please check if the brake is pressed	If it is pressed, release the brake
			The connecting wire between the braking and the instrument is not checked for short circuit or open circuit
			Open circuit or short circuit - need to replace the connecting wire
			Replace the brake handle
Handle failure	E3	Please check if the handle is pressed	If it is pressed, release the handle
			If not, please check the connecting wire between the handle and the instrument for short circuit or open circuit
			Replace the connecting wire for open circuit or short circuit
			Replace the handle
Controller failure	E5	If the controller is damaged, replace the controller	
Tx communication failure	E7	Check the communication line	

Note: Check regularly to ensure that screwed parts are indeed screwed in tightly, in particular the axle, folding system, steering system and brake shaft.

## 17 Maintenance

---

### Lubrication

During maintenance, add a small amount of grease or lubricant to the folding part. You should do this every six (6) months, and check every three (3) months to determine whether any screws used to assemble the scooter have come loose, and tighten any loose screws.

### Battery

When you first acquire the electric scooter, please charge the battery fully before use. Charging will not damage the battery. If this product is not used for a long time, please be sure to charge it at least once every 3 months

### Storage and daily maintenance

Daily maintenance should be performed indoors. Please do not leave the scooter in the hot sun or in a wet or humid place for an extended period of time. Please keep the scooter clean. Do not clean the product using a high pressure gun. Please do not scrub using corrosive detergent.

### Do not make any modification

Please do not refit or modify the scooter in any way, including the steering pipe and sleeve, rod, folding parts and rear brake assembly.

### Warning!

- 1) It is recommended that you check the folding device, shock absorber, wheel and axle of the scooter on a regular basis. If you discover wear, please replace the affected part in time.
- 2) It is recommended that you check the frame and front fork on a regular basis. Long term use may lead to the screws becoming loose. Clean and tighten the screws regularly.
- 3) Please replace the parts should any of them stop working properly.
- 4) Once the parts have outlived their expected service life, please replace them as soon as possible.

## 18 Common problems and solutions

---

Should the product break down or malfunction, please refer to the following for a potential solution:

1. The display screen is black

Reason: the product has been exposed to a sunlamp for a prolonged period of time.

Solution: place the product in a cool location for a while.

3. The digital display is dim

Reason: poor battery contact or no battery power.  
Solution: turn off the power first, and then turn it on again. If the malfunction continues after the battery has been charged, please contact the manufacturer or dealer.

5. The controller is damaged. Do not replace the controller without authorization.

Please contact the manufacturer or distributor, do not disassemble the product without authorization

2. The value displayed is inconsistent with the actual value

Reason: incorrect or missing parameter setting.  
Solution: press and hold down the power key to turn off and then press again to restart the slide.

4. If the product does not operate in normal fashion, please check whether the following work has been completed:

- a. Check that the power is on.
- b. Check the battery power in the display.
- c. Check whether the left brake handle and rear brake disc are in place.
- d. Make sure that all sockets and connection holes are properly connected.

If, the product still does not work properly once all of these steps have been completed, please contact the manufacturer or dealer.

6. There is slamp shaking in the vertical pole

Reason: the screw at the joint of the vertical pole and the folding seat is loose.

Solution: put down the pole, loosen the three screws, then erect the pole again, tighten the screws at the back of the pole, and then put down the pole and tighten the three loose screws to solve the problem.

## 19 Parameter configuration

Parameter	Name	NAVEE scooter N65
Size	Vehicle deployment: L*W*H	1190*510*1220mm
	After folding: L*W*H	1210*205*460mm
Weight	Net weight	About 23.5kg
State	Max capacity	120kg
Main parameter	Maximum speed	20mph (32 km/h)
	Full power endurance	30-65km (depends on the environment, angle, speed, driving habits, etc.)
	Maximum climbing	About 25%
	Scope of application	The road surface used for riding the scooter should be flat and smooth, any bulges in the road surface should be less than 2 cm in height, and any depressions should be less than 3 cm in height
	Tyre	10 inch pneumatic tyre
	Damping system	Front and rear pneumatic tyre damping
	Noise test	Less than 70 dB
	Protection grade	IPX4
	Brake system	Rear wheel disc braking + front wheel (motor) electromagnetic brake, braking distance < 5m (20km / h)
	LED display	Gear, real-time speed, Bluetooth, braking force, automatic cruise, walking mode, electric quantity, total mileage, single trip mileage, mileage, fault display, headlight status indicator, refueling force, speed unit, voltage display, locking, mileage unit
	Lamp system	LED front and rear lamps
	Motor power	500W
Charging parameters	Adapter Charging	54.6 V/2A/short circuit protection
	Lithium battery	48V-12.5AH
	Charging time	About 7-8h

## 20 Warranty and service

### Warranty Statement:

If the product is within the warranty period from the date of your purchase, we will repair, replace or return it free of charge as the case may be if it is confirmed by the manufacturer or dealer that it is faulty or damaged due to quality defects under normal use. Unless otherwise specified by relevant laws, the product or component used for replacement may not be new, but nevertheless performs well and is equivalent, at least, to the original product or component in function. The warranty period is calculated from the first date of purchase of the product, subject to the invoice date. If there is no valid invoice, the warranty period shall be calculated from the date of delivery plus thirty (30) days. If the invoice date is later than the actual delivery date of the product, the warranty period shall be calculated from the actual delivery date. The repaired or replaced products shall continue to enjoy the warranty for the rest of the warranty period, but not less than thirty (30) days. For warranty application, please contact the manufacturer or distributor of the product and follow the instructions. When applying for warranty, an accurate, complete and clear valid sales invoice should be provided.

The above warranty does not apply to failure, malfunction or damage caused by: (a) misuse, abuse or improper transportation, maintenance or storage, such as but not limited to use, storage or maintenance under improper temperature, humidity or other improper environmental conditions; (b) force majeure or accidents, network or power interruption and other reasons beyond our reasonable control; (c) repair or removal without authorization from the manufacturer; (d) the way in which damage has been caused by any third party products or services shall be specified ( purposes other than those for which the product has been designated or intended: (f) using the product in violation of the product instructions: (g) using the product for commercial purposes; or (h) the accumulated mileage recorded by the scooter body has exceeded 2000 km. Normal wear and tear or aging, scratches, abrasions and problems caused by the use of coatings, solvents or other chemicals during general use of the product do not fall within the scope of the warranty. If the original identification label of the product is changed or damaged, this warranty will be invalid. The integrity and completeness of the products and of the attached materials are not within the scope of the warranty.. You should inspect the products on the spot when receiving them and object immediately to any ascertained discrepancy/ies.

The above warranty statement applies to our products. This warranty grants the specific legal rights and other rights you may have according to the law. Nothing in this document affects your rights in a fashion that is not susceptible of exclusion or restriction in accordance with law.

---

Warranty information for the product:

Type	Warranty content	Warranty period
Controller	Controller assembly and central warehouse dashboard	12 months
Lithium battery	Lithium battery pack and protection board	12 months
Main body	Frame assembly, hub motor, front body, rear hub, brake assembly, folding assembly, vertical bar, front fork, rear fork, vertical bar rotating parts, control bus, braking line	12 months
Enclosure	Charger, brake handle, thumb accelerator	6 months

**Reminder: The following consumables delivered with the scooter upon purchase are not covered by the warranty: inner and outer tires, front lamp assembly, instrument cover, handle cover, fender, rear tail lamp, decorative cover, foot support, charging port seat, rubber plug and scooter kit. When repairing and replacing parts, do not use any replacement parts other than professional parts provided by the original manufacturer. For replacement, please contact the manufacturer.**

## 21 Warranty card

When purchasing the product, we recommend that you clearly fill in the following information and affix the sales seal to protect your legitimate rights and interests:

User's information	Full name		E-mail	
	Mailing address			
	Contact number		Postal Code	
Product information	Name of the product		Sales date	
	Product model		Invoice number	
Vendor information	Name		Contact number	
	Address		Postal Code	
Note: (1) This form shall be confirmed by the seller's seal (2) For products applicable to relevant "three guarantees" regulations, this warranty card is equivalent to "three guarantees certificate": (3) The maintenance record is subject to the voucher issued by the authorized service organization. Please keep it in a safe place after applying for service.				

### Warning!

This product is the same as any mechanical parts. The scooter can bear high stress and wear. Various (scooter's machinery, axle) materials and components may react differently to wear or fatigue. If the component has reached its expected service life, it may break suddenly, thereby creating a risk of personal injury. If any any problems are discovered, please repair and replace the parts as soon as possible. If cracks, scratches and/or discoloration are discovered in the area under high pressure, this indicates that the component has exceeded its service life. Please contact the manufacturer or dealer to replace the component as soon as possible.